

PCB Layout and Design Considerations for CH7012 TV Output Device

Introduction

This application note focuses on the basic PCB layout and design guidelines for the CH7012 TV Output Device. Guidelines in component placement, power supply decoupling, grounding, and reference crystal placement and selection, input signal interface and video Components for CH7012 implementation to drive TV video output, are discussed in this document. The guidelines discussed here are intended to optimize the PCB layout and applications for this product. They are only for references. Designers are urged to implement the configurations and evaluate the performance of the system prior to bringing the design to production.

The discussion and figures that follow reflect and describe connections based on the 64-pin LQFP package of CH7012. Please refer to CH7012 data sheet for the details of the pin assignments.

Component Placement

Components associated with the CH7012 Encoder should be placed as close as possible to the respective pins. The following discussion will describe guidelines on how to connect critical pins, as well as describe the guidelines for the placement and layout of components associated with these pins.

• Power Supply Decoupling

The optimum power supply decoupling is accomplished by placing a 0.1 μ F ceramic capacitor to each of the power supply pins as shown in **Figure 1**. These capacitors (C7, C8, C9, C11, C12, C14, C15, C17) should be connected as close as possible to their respective power and ground pins using short and wide traces to minimize lead inductance. Whenever possible, a physical connecting trace should connect the ground pins of the decoupling capacitors to the CH7012 ground pins, in addition to ground vias.

◆ Ground Pins

The analog and digital grounds of the CH7012 should connect to a common ground plane to provide a low impedance return path for the supply currents. Whenever possible, each of the CH7012 ground pins should connect directly to its respective decoupling capacitor ground lead, then connected to the ground plane through a ground via. Short and wide traces should be used to minimize the lead inductance. See **Table 1** for the Ground pins assignment.

◆ Power Supply Pins

Separate digital (including the I/O supply voltage DVDDV), Analog, and DAC power planes are recommended. See **Table 1** for the Power supply pins assignment.

Table 1: Power Supply Pins Assignment in CH7012

Pin Assignment	# of Pins	Type	Symbol	Description	Voltage Rating
1, 12, 49	3	Power	DVDD	Digital Supply Voltage	+3.3v
6, 11, 64	3	Power	DGND	Digital Ground	
45	1	Power	DVDDV	I/O Supply Voltage	+3.3v ~ +1.1v
18, 44	2	Power	AVDD	PLL Supply Voltage	+3.3v
16, 17, 41	3	Power	AGND	PLL Ground	
33	1	Power	VDD	DAC Supply Voltage	+3.3v
34, 40	2	Power	GND	DAC Ground	

◆ DVDDV & VREF Decoupling and Connection

VREF is used as a reference level for pixel data input D[11:0], H sync input, V sync input, P-Out output. For the optimum decoupling, please refer to **Figure 2**.

In general application, VREF is derived from DVDDV divided by 2, i.e., $VREF = 1/2 \times DVDDV$. Therefore, in **Figure 2**, both resistors should have the same value (10KΩ@ 1%). The decoupling capacitor is required as shown in **Figure 2**. Also the DVDDV voltage supply should be connected to the graphics controller I/O VDD.

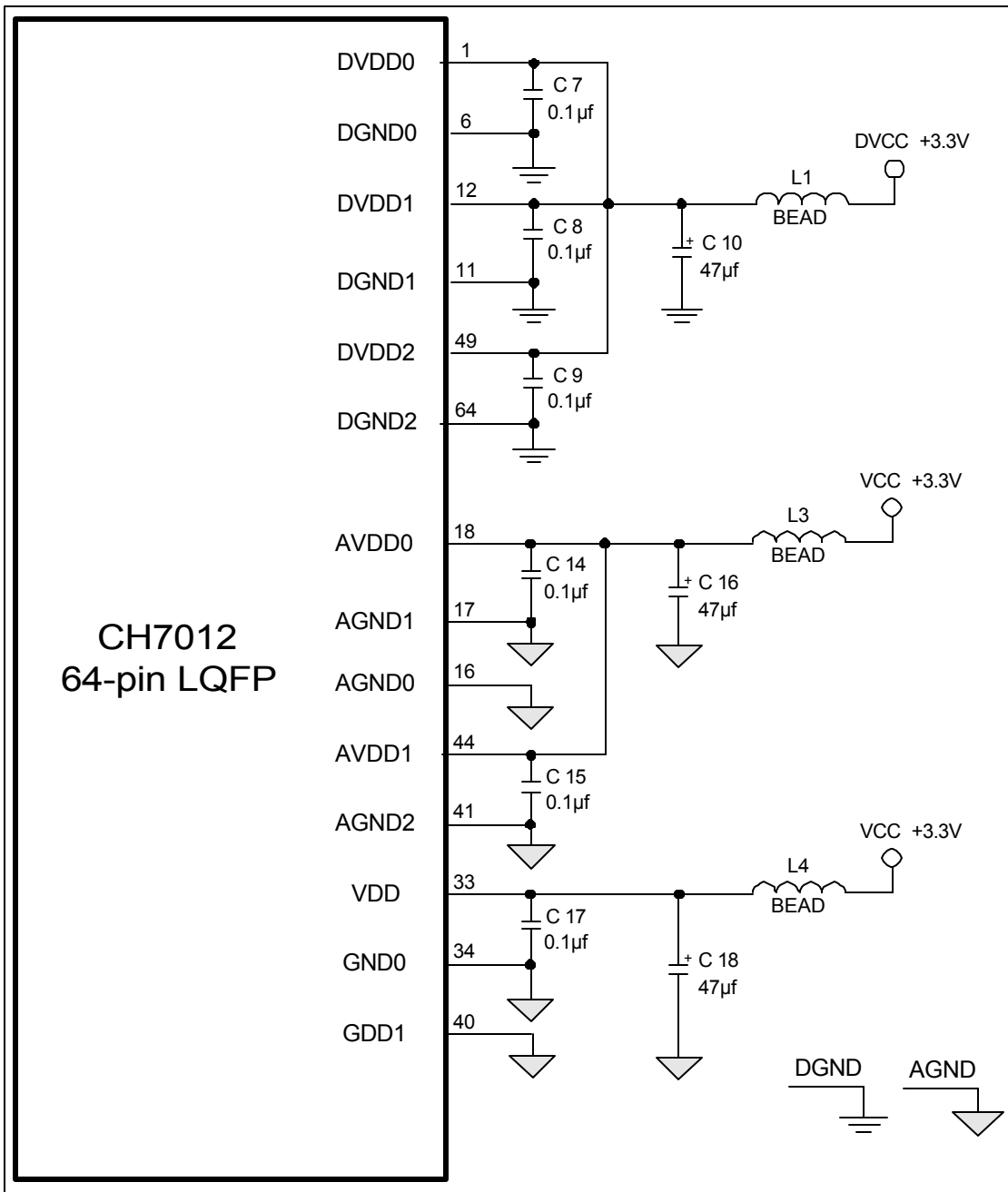

Figure 1: Power Supply Decoupling and Distribution

Notes: All the Ferrite Beads described in this document are recommended to have <.05ohm at DC; 23ohm at 25MHz & 47ohm at 100MHz. Please refer to Fair_Rite part# 2743019447 for detail or an equivalent part can be used for the diagram.

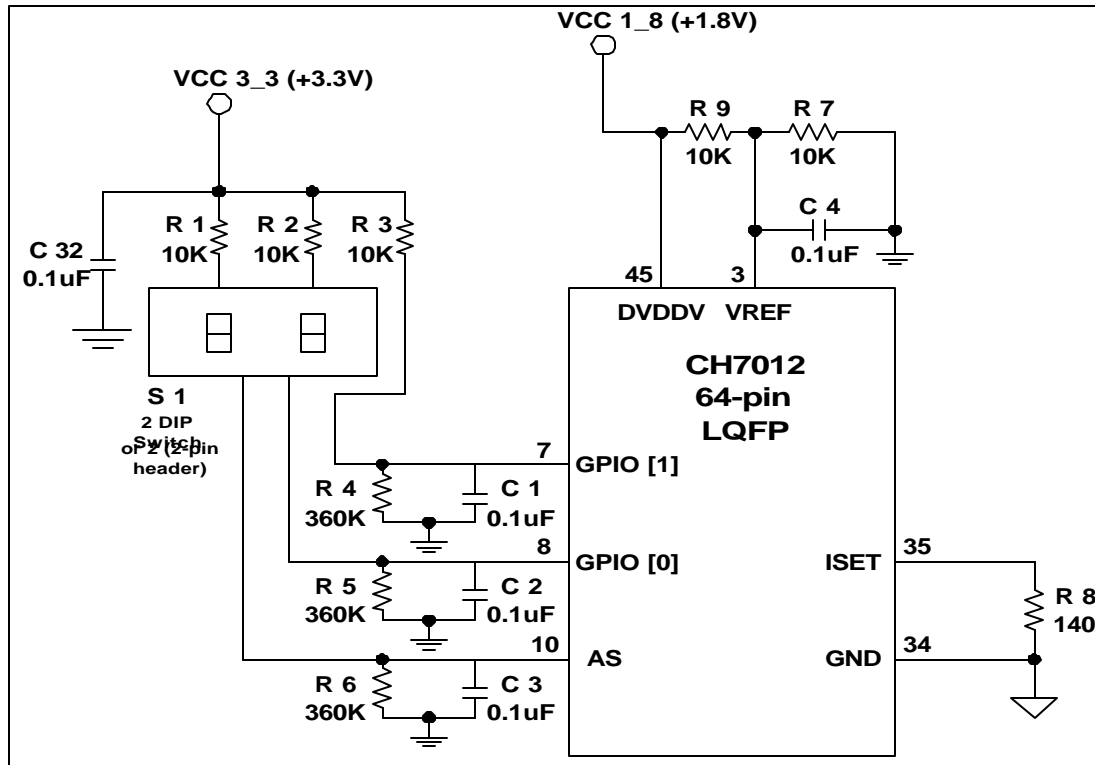

Figure 2: (1) ISET, VREF and DVDDV Connection; (2) GPIO and AS connection

• General Controls and Inputs

◆ ISET pin

A 140Ω resistor should be placed directly and as close as possible to Pin 35 with short and wide traces. Whenever possible, the ISET resistors ground pin should also be connected to the pin 34. Otherwise, the ground reference of the ISET resistor should ideally be close to the CH7012. See **Figure 2** for design reference.

◆ GPIO [0] & GPIO[1] pins

In applications using Intel i815 or Intel i810 chipset* and the Intel software driver, it is recommended that the Pins 7 and 8 for GPIOs should be configured as shown in **Figure 2**. GPIO[0] is used to select NTSC (GPIO[0] = high) or PAL (GPIO[0] = low) in TV Out mode. GPIO[1] is reserved for future use and has no function in the current version.

◆ AS pin

Pin 10 Address Select should be configured as shown in **Figure 2**. This pin determines the serial port address of the device is either 0x75 (AS= low) or 0x76 (AS= high).

◆ Horizontal and Vertical Sync Signals (HSYNC and VSYNC)

In input modes where the horizontal and vertical sync signals from the graphics controller are shared between the CH7012 and the computer monitor, buffering the sync signals prior to connecting them to the monitor is recommended (please refer to **Figure 3** below). These buffers help isolate any noise generated from the monitor connection (e.g., reflections, etc.) from coupling into the sync inputs of the CH7012, thereby degrading the display quality. In modes where the embedded syncs are used, these buffers are not necessary.

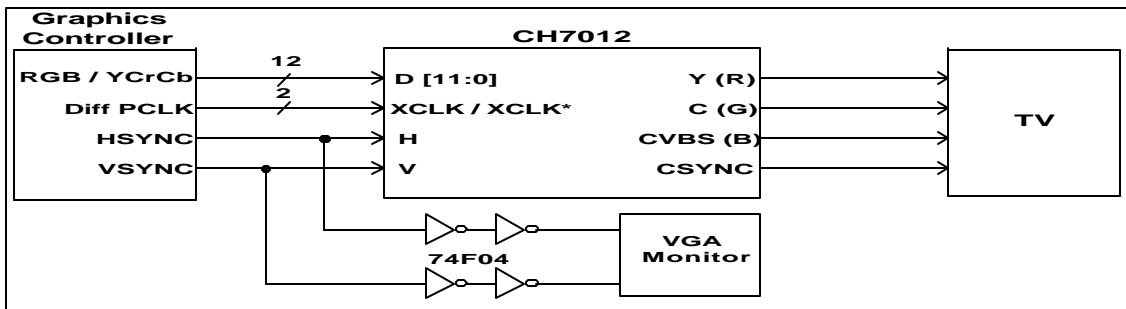

Figure 3: Sync Buffers

Note: If differential pixel clock from the graphics controller is not available, XCLK* should be tied to VREF.

◆ **Video Inputs (D[0:11])**

Since the digital pixel data and the pixel clock of the CH7012 may toggle at speeds up to 165MHz (depending on input mode), it is critical that the connection of these video signals between the graphics controller and the CH7012 be kept short and isolated as much as possible from the analog outputs and analog circuitry. For optimum performance, these signals should not overlay the analog power or analog output signals. The DATA signals are single ended high speed signals that should be routed together as a bus. It is recommended that 8 mil traces be used in routing these signals.

◆ **Pixel Clock Mode**

Depending on the architecture and configuration of the graphic controller, CH7012 may have different clock modes settings. In all these modes, H sync, V sync and pixel data D[11:0] must meet the setup and hold time with respect to pixel clock.

♣ **Master Clock Mode**

P-Out pin outputs a pixel clock to the graphic controller. To set the Master Clock Mode for CH7012, Bit 3 of Register CM (1Ch) should set to 1. The 14.31818MHz clock is then used as a frequency reference in the TV PLL.

Bit 0 of register CM signifies the XCLK frequency. A value of 0 is used when the XCLK is at the pixel frequency (dual edge clocking mode) and a value of 1 is used when the XCLK is twice the pixel frequency (single edge clocking mode).

Bit 1 of register CM controls the P-Out clock frequency. A value of 0 generates a clock output at the pixel frequency, while a value of 1 generates a clock at twice the pixel frequency.

Bit 2 of register CM controls the phase of the XCLK clock input to the CH7012. A value of 1 inverts the XCLK signal at the input of the device. This control is used to select which edge of the XCLK signal to use for latching input data.

The direction of H sync and V sync signal can be controlled by Sync Register 1Fh. When the bit5 (SYO) = 0, the Hsync and V sync signals are input to CH7012. When the bit5 (SYO) = 1, the H sync and V sync signals are output to graphics controller. It is recommended to configure CH7012 in this clock mode with SYO set to 0 when the application use with the Intel i815 or Intel i810 chipset* (See **Figure 4** for design details).

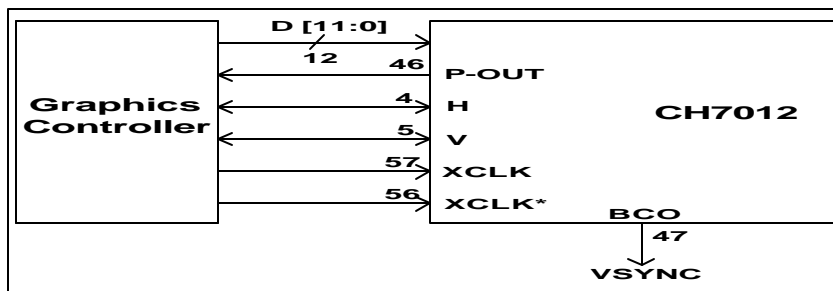

Figure 4: Master Clock Mode

♣ **Buffered Clock Output (BCO)**

The clock output from Pin 47 BCO (Buffered Clock Output) is controlled by BCO register (22h). Bits 2-0 select the signal output (see Table 2).

Table 2: BCO Output Signal

BCO[2:0]	Buffered Clock Output	BCO[2:0]	Buffered Clock Output
000	The 14MHz crystal	100	Sine ROM MSB
001	UCLK	101	Cosine ROM MSB
010	VCO divided by K3	110	VGA Vertical Sync
011	Field ID	111	TV Vertical Sync

♣ **Slave Clock Mode**

For this mode, select register 1Ch (Clock Mode Register, CM) bit 3 = 0. The pixel clock comes from the graphic controller and the P-Out can be set to a high impedance state. The XCLK input is then used as a reference to the TV PLL. The direction of H sync and V sync signal can be controlled by Sync Register 1Fh. When the bit5 (SYO) = 0, the H sync and V sync signals are input to CH7012. When the bit5 (SYO) = 1, the H sync and V sync signals are output to graphic controller. It is recommended to configure CH7012 in this clock mode with SYO set to 0 when the application use with the Intel i815 or Intel i810 chipset* (See Figure 5 for design details).

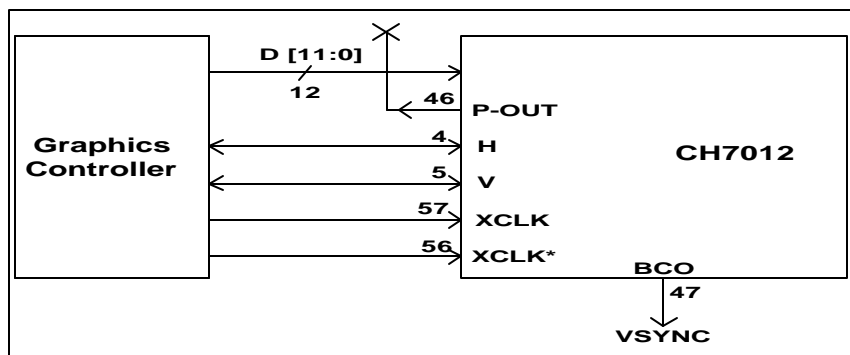

Figure 5: Slave Clock Mode

♣ **Embedded Sync Mode**

In order to enable this mode, Input Data Format Register 1Fh needs to be set for IDF = 4. Since H sync and V sync signals can be embedded into the data stream, the connections of H sync and V sync pins are not required between the graphic controller and CH7012. Please refer CCIR656 for details on how the H sync and V sync, odd field & even field signals are generated within the data stream (See Figure 6 for design details for embedded sync in slave clock mode. Please note that the master clock mode can also be used.).

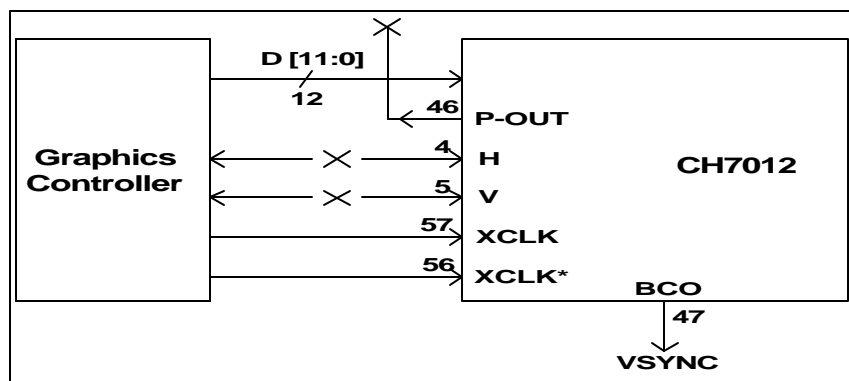

Figure 6: Embedded Sync (in slave clock) Mode

◆ Crystal Input

The 14.31818 MHz ($\pm 20\text{ppm}$) crystal must be placed as close as possible to the XI/FIN and XO pins (Pins 42 and 43), with traces connected from point to point, overlaying the ground plane. Since the crystal generates timing reference for the CH7012 encoder, it is very important that noise should not couple into these input pins. Traces with fast edge rates should not be routed under or adjacent these pins. In addition, the ground reference of the external capacitors connected to the crystal pins must be connected very close to the CH7012 pin 41 ground (See **Figure 7**).

◆ Reference Crystal Oscillator

The CH7012 includes an oscillator circuit which allows an inexpensive 14.31818MHz crystal to be connected directly. Alternatively, an externally generated 14.31818MHz clock source may be supplied to the CH7012. If an external clock source is used, it should have CMOS level specifications. The clock should be connected to the XI/FIN pin, and the XO pin should be left open. The external source must exhibit $\pm 20\text{ppm}$ or better frequency tolerance, and possess low jitter characteristics.

If a crystal is used, the designer should ensure that the following conditions are met:

- Crystal is specified as 14.31818 MHz, $\pm 20\text{ppm}$ fundamental type and in parallel resonance (NOT series resonance).
- Crystal is operated with a load capacitance equal to its specified value (C_L).
- External load capacitors have their ground connection very close to the CH7012 (C_{ext}).
- To allow tunability, a variable cap may be used from XI/FIN to ground.

Note that the XI/FIN and XO pin each has approximately 10 pF (C_{int}) of shunt capacitance internal to the device. To calculate the proper external load capacitance to be added to the XI/FIN and XO pins, the following calculation should be used:

$$C_{ext} = (2 \times C_L) - C_{int} - 2C_S$$

where:

C_{ext} = external load capacitance required on XI/FIN and XO pins.

C_L = crystal load capacitance specified by crystal manufacturer.

C_{int} = capacitance internal to CH7012 (approximately 10-15 pF on each of XI/FIN and XO pins).

C_S = stray capacitance of the circuit (i.e. routing capacitance on the PCB, associated capacitance of crystal holder from pin to pin etc.).

Please refer to **Figure 7** for the symbols used in the calculation described above.

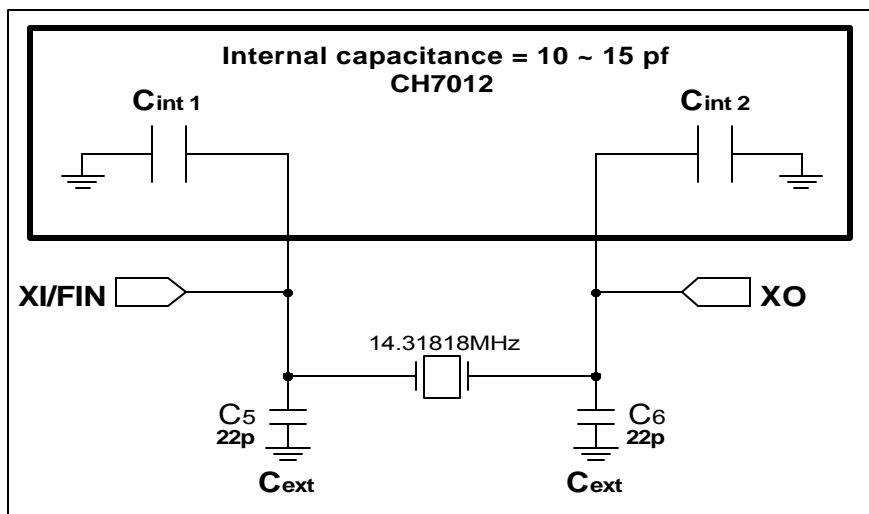

Figure 7: Reference Crystal

$$C_L = \frac{(C_{int\ XI/FIN} + C_{ext\ XI/FIN}) (C_{int\ XO} + C_{ext\ XO})}{C_{int\ XI/FIN} + C_{int\ XO} + C_{ext\ XI/FIN} + C_{ext\ XO}} + C_S$$

In general , let us assume

$$C_{int\ XI/FIN} = C_{int\ XO} = C_{int}$$

$$C_{ext\ XI/FIN} = C_{ext\ XO} = C_{ext}$$

such that

$$C_L = (C_{int} + C_{ext}) / 2 + C_S \text{ and } C_{ext} = 2 (C_L - C_S) - C_{int}$$

$$= 2 C_L - (2C_S + C_{int})$$

Therefore C_L must be specified greater than $C_{int} / 2 + C_S$ in order to select C_{ext} properly.

Drive level

After C_L (crystal load capacitance) is properly selected, care should be taken to make sure the crystal is not operating in excessive drive level specified by crystal manufacturer. Otherwise, the crystal will age quickly and that in turn will affect the operating frequency of the crystal.

$$\text{Drive level} = 1/2 (2\pi f x C_L x V)^2 x R_S$$

R_S : Motion resistance in Ω . (< 50 Ω)

V : Operating voltage of crystal oscillator circuit.

f : Crystal operating frequency (14.31818 MHz).

For the detail consideration of crystal oscillator design, please refer AN-06.

◆ TV Video Outputs

In TV Output mode, multiplexed input data, sync and clock signals are input to the CH7012 from the graphics controller’s digital output port. A P-Out clock can be output as a frequency reference to the graphics controller, which is recommended to ensure accurate frequency generation. Horizontal and vertical sync signals are normally sent to the CH7012 from the graphics controller, but can be output to the graphics controller as an option (this is not recommended for pixel rates above 50MHz). Data will be 2X multiplexed, and the XCLK clock signal can be 1X or 2X times the pixel rate. The input data will be encoded into the selected video standard, and output from the video DACs. The modes supported for TV output are shown in the table below.

Table 3: TV Output Modes

Graphics Resolution	Active Aspect	Pixel Aspect	TV Output	Scaling Ratios
	Ratio	Ratio	Standard	
512x384	4:3	1:1	PAL	5/4, 1/1
512x384	4:3	1:1	NTSC	5/4, 1/1
720x400	4:3	1.35:1.00	PAL	5/4, 1/1
720x400	4:3	1.35:1.00	NTSC	5/4, 1/1
640x400	8:5	1:1	PAL	5/4, 1/1
640x400	8:5	1:1	NTSC	5/4, 1/1, 7/8
640x480	4:3	1:1	PAL	5/4, 1/1, 5/6
640x480	4:3	1:1	NTSC	1/1, 7/8, 5/6
720x480 ¹	4:3	9:8	NTSC	1/1
720x480 ²	4:3	9:8	NTSC	1/1, 7/8, 5/6
720x576 ¹	4:3	15:12	PAL	1/1
720x576 ²	4:3	15:12	PAL	1/1, 5/6, 5/7
800x600	4:3	1:1	PAL	1/1, 5/6, 5/7
800x600	4:3	1:1	NTSC	3/4, 7/10, 5/8
1024x768	4:3	1:1	PAL	5/7, 5/8, 5/9
1024x768	4:3	1:1	NTSC	5/8, 5/9, 1/2

The 75Ω output termination, the output filter network, and the output connectors should be located as close as possible to the CH7012 to minimize the noise pickup as well as possible reflections due to impedance mismatches. The video output signals should overlay the ground plane and should be routed away from digital lines that could introduce crosstalk. The Y and C outputs should be separated by a ground trace and inductors and ferrite beads in series with these outputs should not be located next to each other.

The recommended output reconstruction filter network is a third order low pass filter. The recommended frequency response and the circuit elements are shown in **Figure 8** and **Figure 9**.

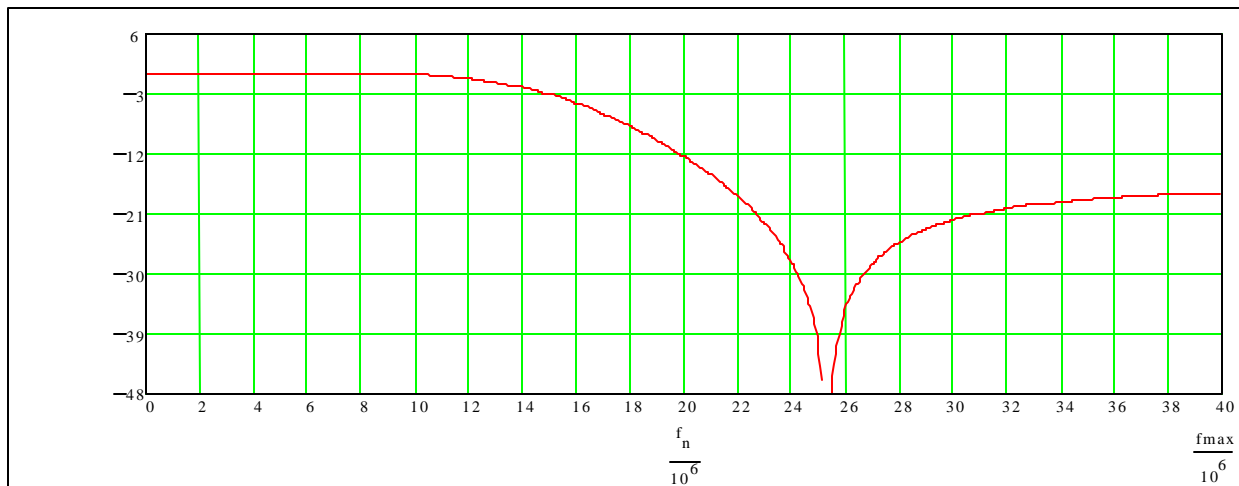

Figure 8: Amplitude Response of the 3rd Order Reconstruction Filter

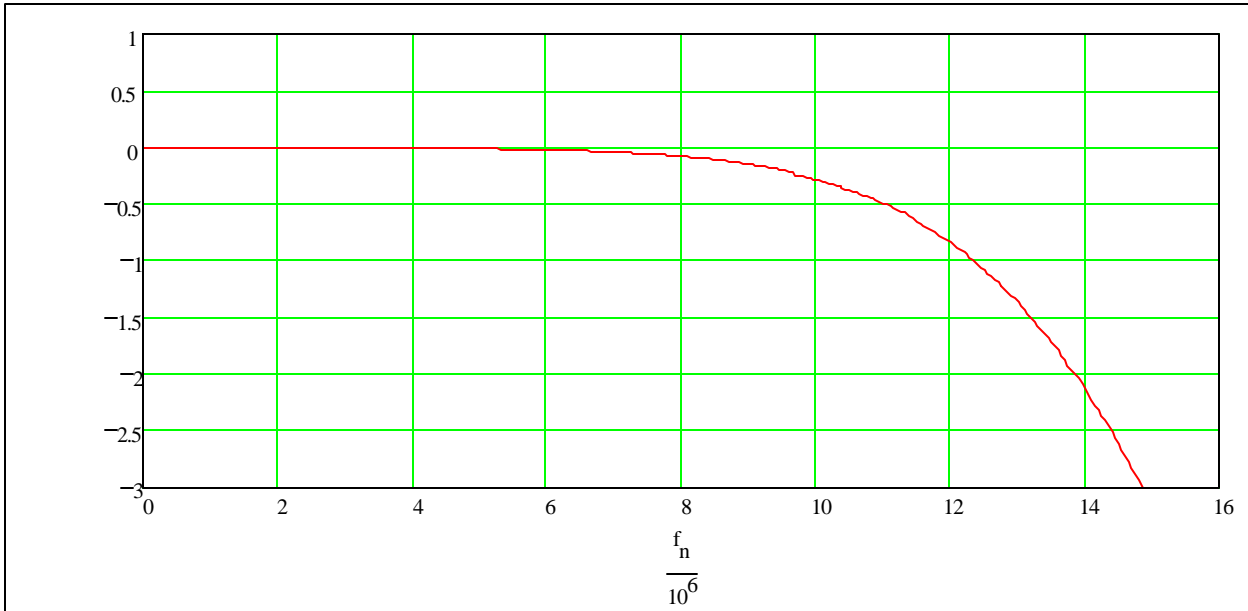

Figure 9: The Details of the Amplitude Response of the Pass Band

The output of the CH7012 may be configured for the following video output types: S-Video, composite, and SCART. **Figure 10** illustrates the typical connection for the S-Video and composite outputs, while **Figure 11** illustrates the connection for the SCART connector. For SCART arrangement 1, set FF Register (address01h) bit6 VOF = 1 and BL Register(address07h) BL [7:0] = 0. For SCART arrangement 2, set VOF = 0, BL [7:0] = 110 and CVBWB = 0 (Register 02h, bit 5).

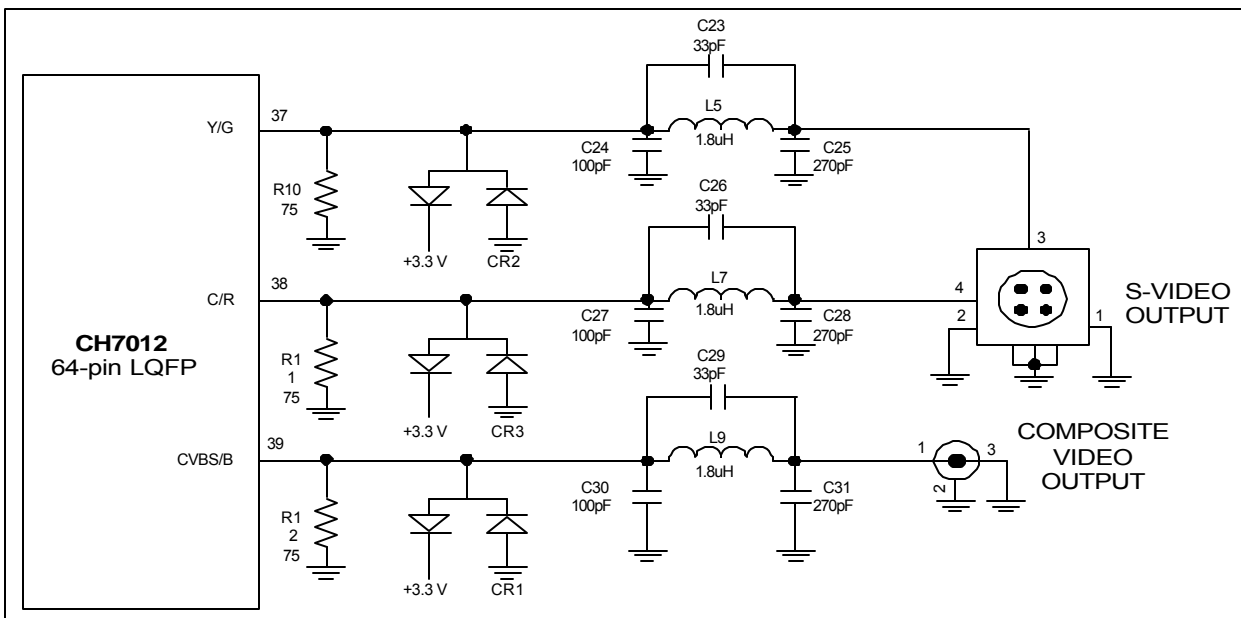

Figure 10: S-Video and Composite Video Outputs

Note: If the application only allows one video output connection and simultaneously display of S-Video and Composite is not needed, please refer AN27 on how to achieve the desire configuration.

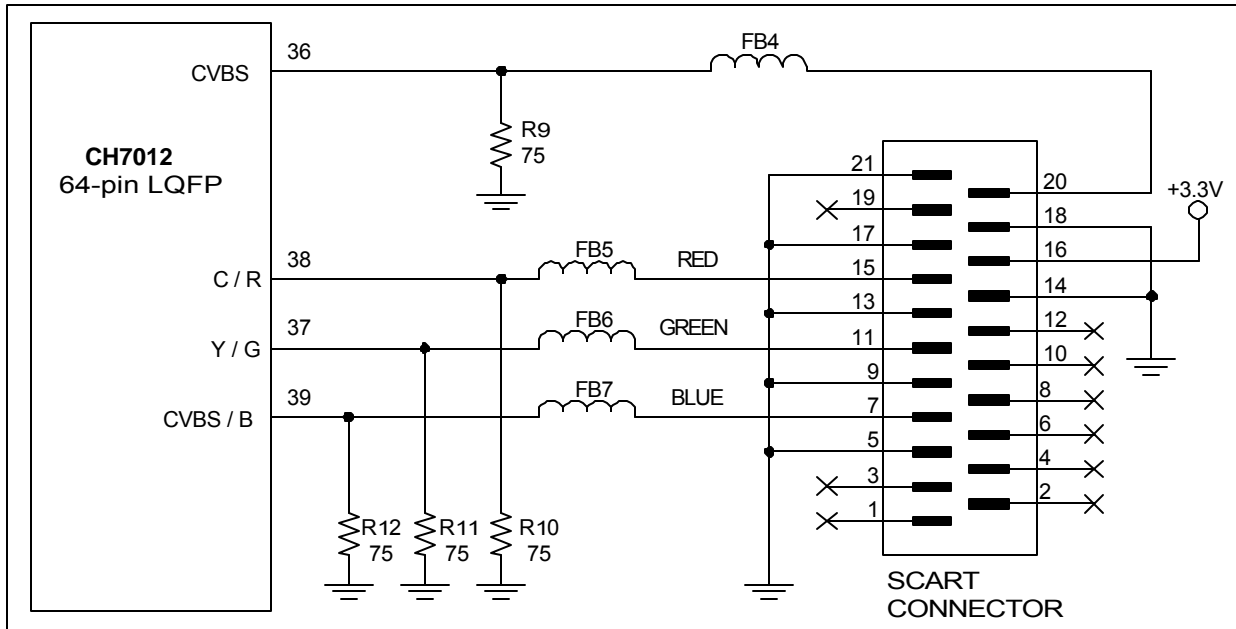

Figure 11: SCART Video Output

Careful layout consideration for the CVBS, Y/G, C/R & CVBS/B traces and the attached components are needed in order to avoid the signal coupling among each other. It is suggested that the signal traces of Y, C and CVBS should be separated with Ground traces and routed to the connectors. Also, the capacitors and the inductors attached to those outputs should not be placed too close to each other.

The CVBS, Y/G, C/R & CVBS/B signals are analog video signals. These signals should be routed using 75 ohm traces. These signals should not be routed together with a minimum of 12 mil spacing between each other and 20 mil spacing between them and any digital trace.

Typically these signals should be routed in a separate analog area without any digital signal running through the area. Corners for these traces should be at a maximum of 45 degrees. 90 degree corners should not be used due to cross coupling between adjacent traces. These traces should be kept on the top layer to minimize the use of vias on them.

The input protection diodes CR1 - CR3 and the series termination resistors R10-R12 should be placed as close to the CH7012 as possible. The low pass filter networks should be placed as close to J1 and J2, the RCA and SVHS connectors as possible to reduce EMI emissions.

Reference Design Example

Attachment 1 shows the schematics for a reference design for the CH7012 implementation to drive TV video output.

Attachments 2 and 3 show the schematics and PCB layout for the CH7012 reference design with full compatibility to CH7009 (TV / FP combo).

Schematics 1 of 2

Attachment 1. Reference Schematics for the implementation of CH7012

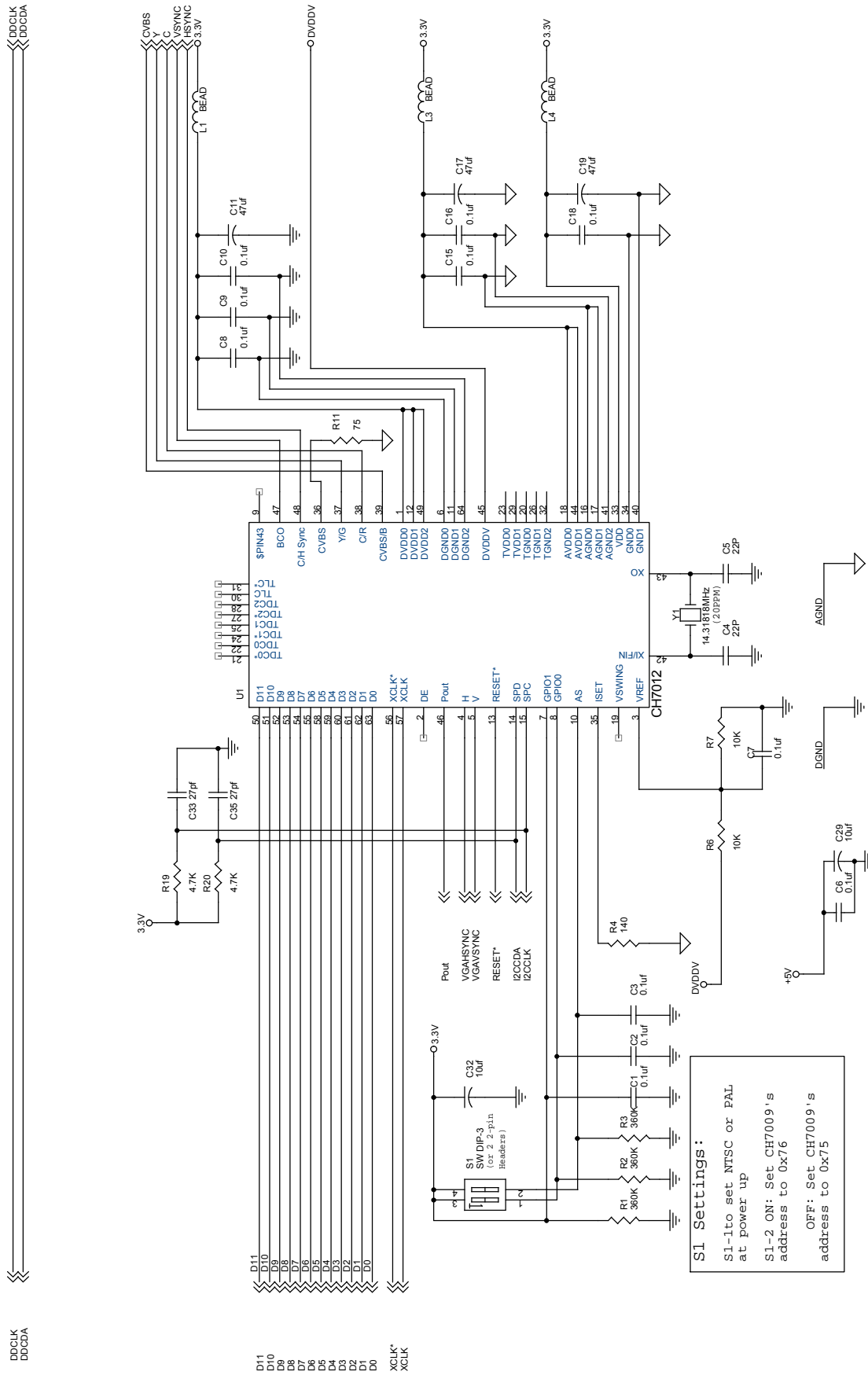

Schematics 2 of 2

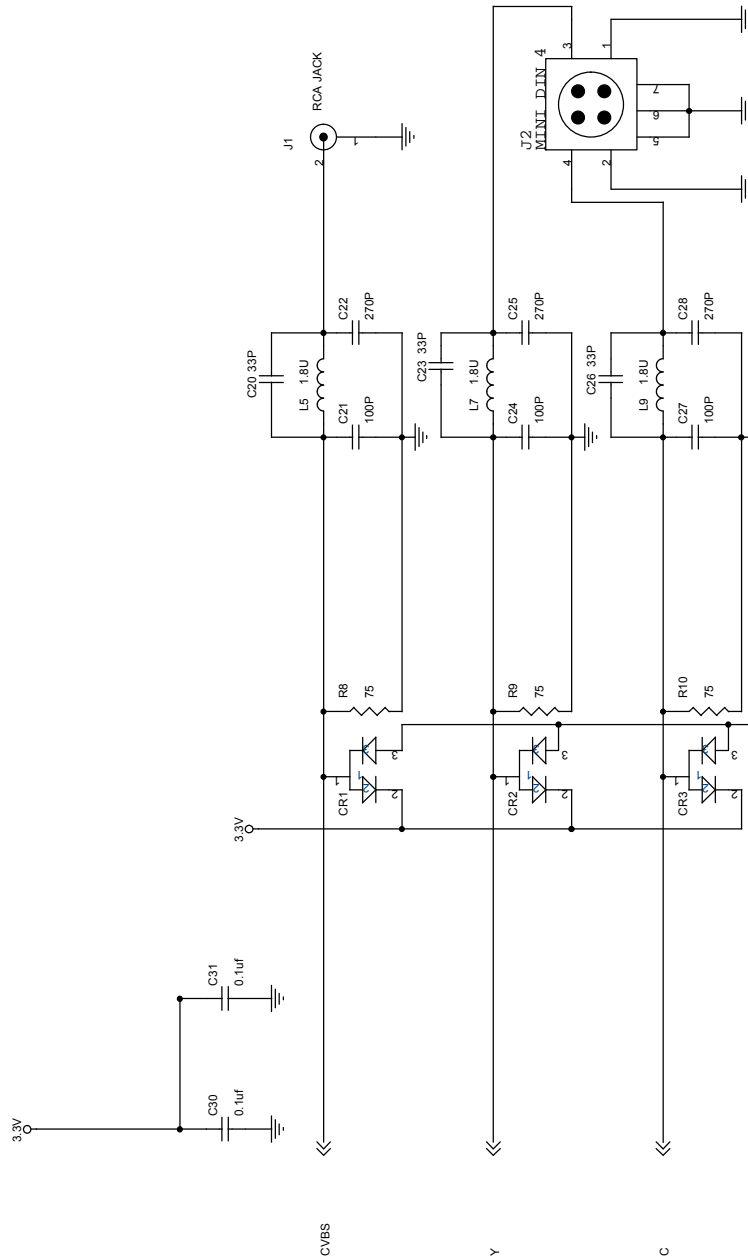

Schematics 1 of 2

Attachment 2. Reference Schematics for the implementation of CH7012 with full compatibility to CH7009 (TV / FP combo)

(Extra componets are added in order to make it fully compatible with CH7009 design.)

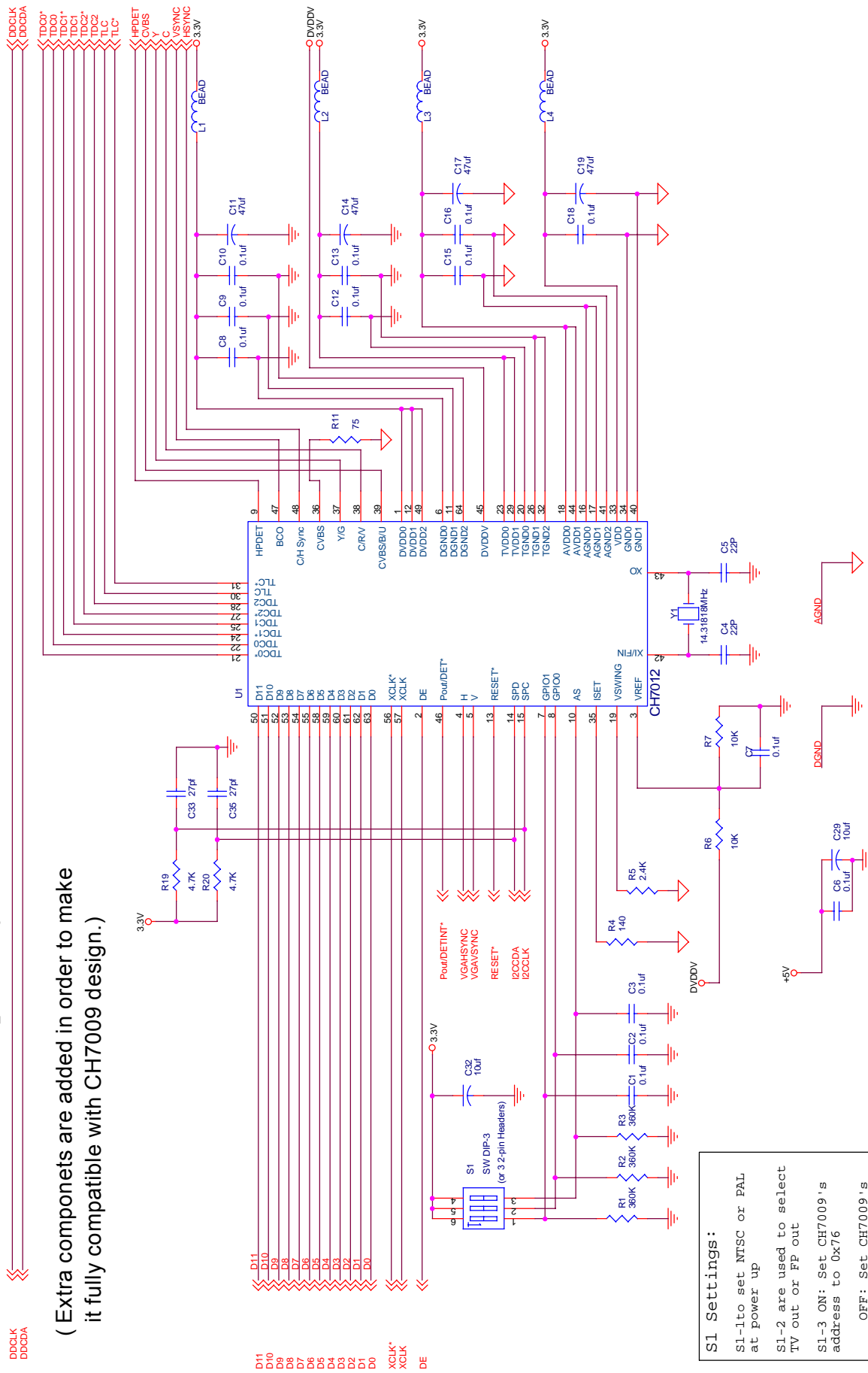

S1 Settings:
 S1-1 to set NTSC or PAL at power up
 S1-2 are used to select TV out or FP out
 S1-3 ON: Set CH7009's address to 0x76
 OFF: Set CH7009's address to 0x75

Schematics 2 of 2

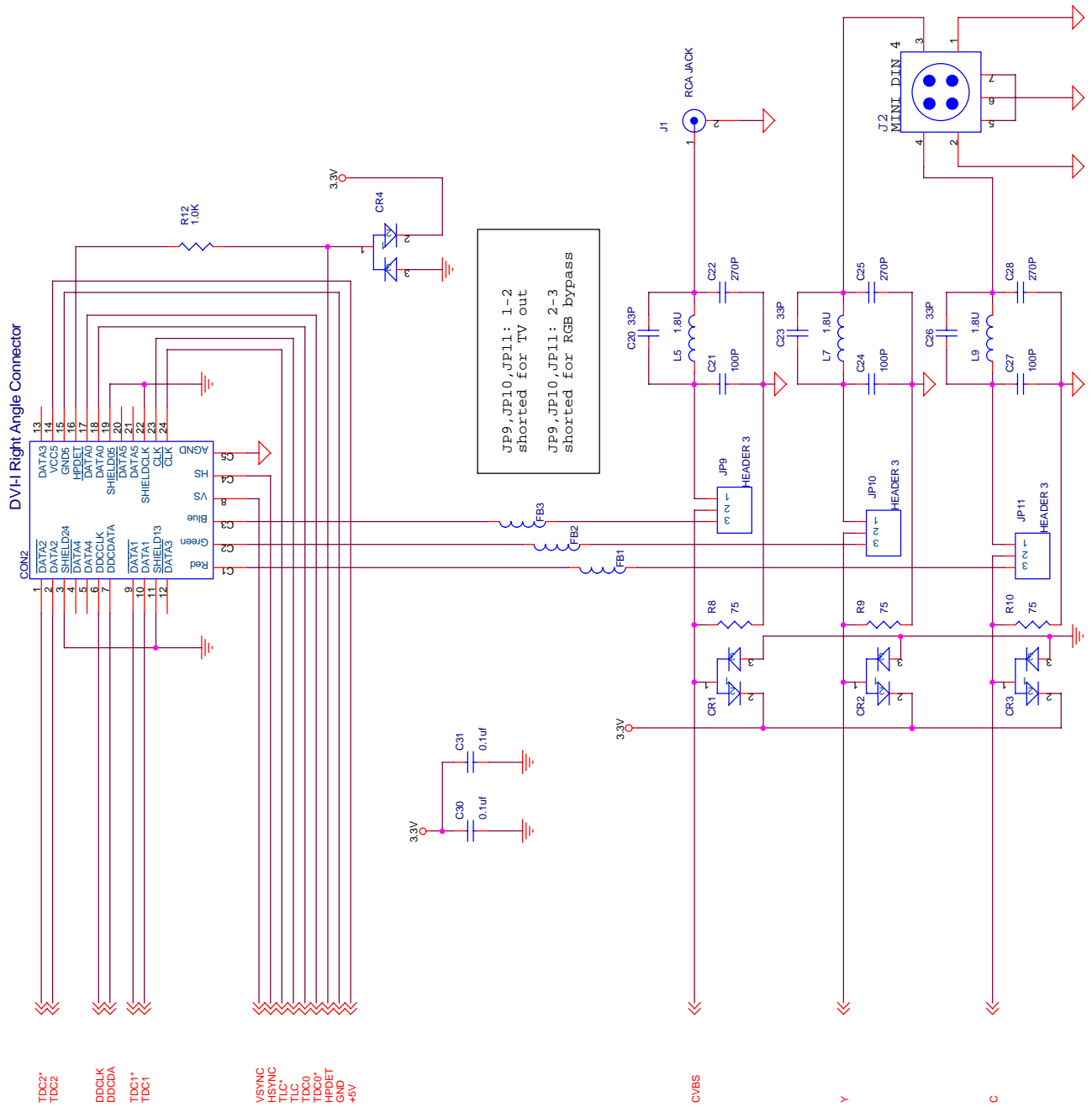

Attachment 3. PCB Layout for the CH7012 Reference Schematics

(The PCB layout is based on the circuit fully compatible with CH7009 design, i.e. with extra components added.)

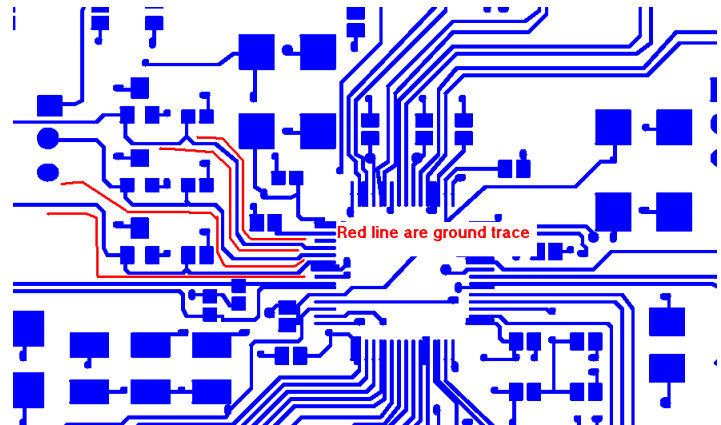

NOTES: UNLESS OTHERWISE SPECIFIED:

1. THIS DOCUMENT ALSO EXISTS ON ELECTRONIC MEDIA.
2. FABRICATE PER INTEL 454979 CLASS 2.
3. DIMENSIONING AND TOLERANCING PER ANSI Y14.5M.
4. SMT LAND PATTERNS THAT HAVE A FINISHED PAD WIDTH RANGING FROM .012" to .015" MUST USE THE FOLLOWING TOLERANCE. +.002/-0.0005.
PCB VENDOR TO ADJUST ARTWORK TO COMPENSATE FOR ETCH PROCESS.

Primary Side

Primary Side	<input type="text"/>	<input type="text"/>
Ground Plane	<input type="text"/>	Nominal Thickness 062" +/-0.005"
Ground Plane	<input type="text"/>	
Secondary Side	<input type="text"/>	

Note: Ground Plane is Duplicated

DRILL CHART				
SYM	DIAM	TOL	QTY	NOTE
◇	0.018		68	
○	0.020		55	
⊕	0.028		102	
×	0.034		6	
⊗	0.035		6	
△	0.037		6	
+	0.038		20	
⊞	0.042		3	
⊞	0.090		5	
○	0.125		2	NDN-PLATED
TOTAL			273	

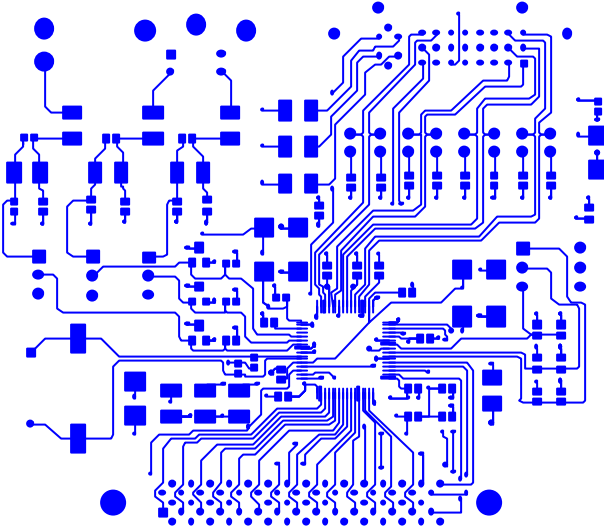

Top side

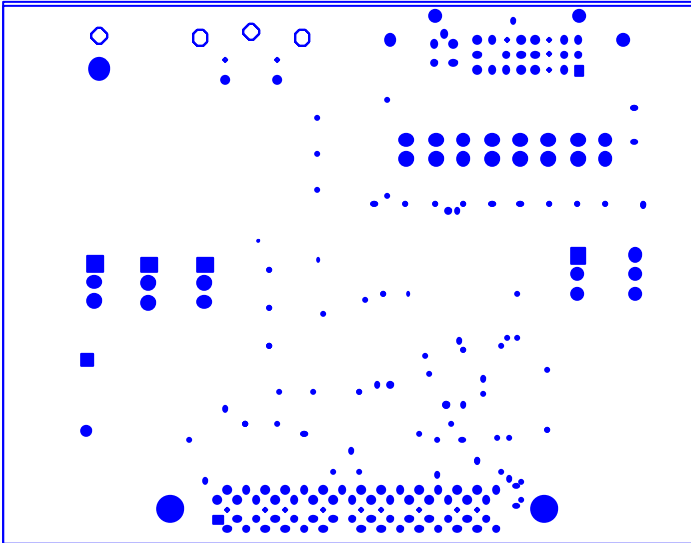

Ground side

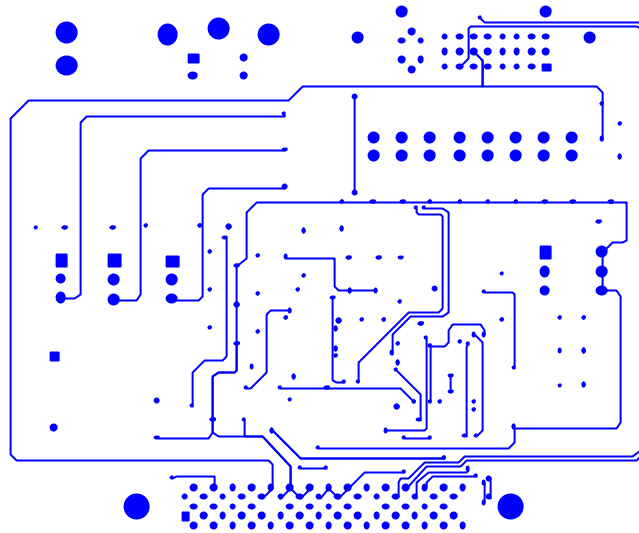

Bottom side

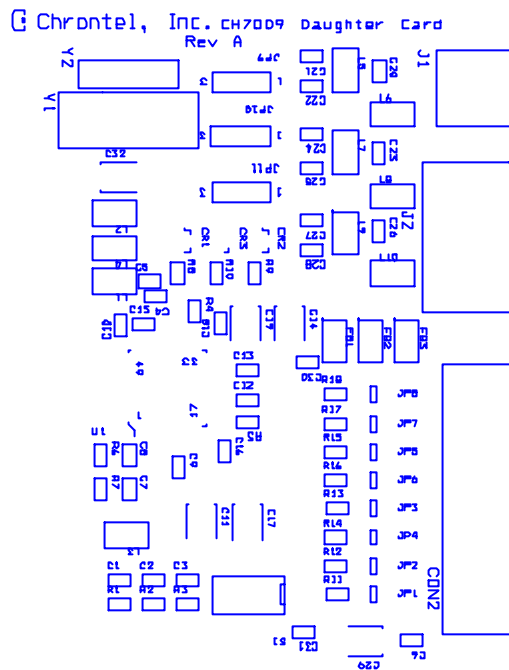

Assembly top side

* It is suggested that in order to prevent the DAC output from cross talk interference, the DAC output should be surrounded by grounding traces.

CH7011/7012 BOMlist (The List is based on the circuit fully compatible with CH7009 design.)

Item	Qty	Reference	Value	Part#
TV/FP Combo Chip Reference Design Revised: W Tuesday, February 11,2000				
CH7009092099 Reversion 0.8				
Bill Of Materials February 28,2000				
1	1	CON1	DVO Connector / Right Angle	AMP# 536295-2
2	1	CON2	DVI-I Vertical Receptacle	Molex # 74320-3004
3	4	CR1,CR2,CR3,CR4	BAV99-DIO-SOT-23	Digi-Key# BAV99Z X CT-ND
4	15	C1,C2,C3,C6,C7,C8,C9,C10, C12,C13,C15,C16,C18,C30,C31	0.1uf/16V 10% X 7R SMT 0603	Anchor# CAP0.1UFSMT-0603
5	2	C4,C5	22PF/50V 5% NPO SMT 0603	Digi-Key# PCC220ACVCT-ND
6	4	C11,C14,C17,C19	47uf/20V Tant Size D	Mouser# 74-594DM16V47
7	3	C20,C23,C26	33PF/50V 5% NPO SMT 0603	Digi-Key# PCC330ACVCT-ND
8	3	C21,C24,C27	100PF/50V 5% NPO SMT 0603	Digi-Key# PCC101ACVCT-ND
9	3	C22,C25,C28	270PF/50V 5% NPO SMT 0603	Digi-Key# PCC271ACVCT-ND
10	2	C29,C32	10uf/20V 20% Y5V SMT 1210	
11	2	C33,C35	27PF/50V 5% NPO SMT 0603	Digi-Key# PCC270ACVCT-ND
12	3	FB1,FB2,FB3	Bead Cores 1210 100MH 39ohm	Mouser436-3600
13			JP1-JP8 removed	
14	3	JP9,JP10,JP11	HEADER 1x 3 single male	Digi-Key# W M2701-ND
15	1	J1	RCA JACK	KLP-0848A-2
16	1	J2	VIDEOJACK	Digi-Key275-1047-ND
17	4	L1,L2,L3,L4	Ferrite Bead 1210	Digi-Key240-1038-1-ND
18	3	L5,L7,L9	1.8UH 10% Ferrite SMT 1210	Digi-k ey# DN10182JCT-ND
19				
20	3	R1,R2,R3	360K 1/16W 5% SMD 0603	Digi-Key# P360KGCT-ND
21	1	R4	140 1/16W 5% SMD 0603	Digi-Key# P140GCT-ND
22	1	R5	2.4K 1/16W 5% SMD 0603	Digi-Key# P2.4KGCT-ND
23	2	R7,R6	10K 1/16W 5% SMD 0603	Digi-Key# P10KGCT-ND
24	3	R8,R9,R10, R1	75 1/16W 5% SMD 0603	Digi-Key# P75GCT-ND
25	1	R12	1.0K 1/16W 5% SMD 0603	Digi-Key# P1.0KGCT-ND
26	2	R19,R20	4.7K 1/16W 5% SMD 0603	Digi-Key# P4.7KGCT-ND